

KUKA



Sensitive robotics_LBR iiwa





LBR iiwa

A feel for the production world of tomorrow

Industrial change is in full swing. IoT and Industrie 4.0 are replacing established structures with a cyber-physical production environment. The active agents in this process of change are intelligent machines with completely new capabilities: robots equipped with sensitivity and superior intelligence. Working side-by-side with humans, they operate more independently and with more sensitivity than ever before. They are mobile, highly flexible and extremely versatile. At the same time, they provide you with seamless digital networking and autonomous adjustment to the rapidly changing production requirements.

KUKA is making the vision of a production environment free from rigid structures into reality. As part of this, lightweight robots (LBR) play a key role as “intelligent industrial work assistants” (iiwa). In a word: LBR iiwa.

40 years after the first industrial robot was used, KUKA is opening a new chapter in the history of industrial robotics with the LBR iiwa.

“LBR” stands for “Leichtbauroboter” (German for lightweight robot), “iiwa” for “intelligent industrial work assistant”. As the first series-produced sensitive robot suitable for human-robot collaboration, the LBR iiwa is opening up new areas that were previously closed to automation.



reddot award 2014
best of the best

Sensitive robotics

_LBR iiwa

ii am sensitive

_The new era of automation is based on sensitivity.	6
_A revolution in robotics	8
_The LBR iiwa in practice	10

ii am safe

_The LBR iiwa also takes safety to a whole new level.	12
_Sensitized for safe working	14
_The LBR iiwa in practice	16

ii am flexible

_The age of individuality is changing industries.	18
_The environment changes, the performance stays the same.	20
_The LBR iiwa in practice	22

ii am precise

_Envisioning the industrial future with precision	24
_Precisely on track, even in the case of changing workpieces	26
_The LBR iiwa in practice	28

_Technical data	30
_Programming. Control. Operation.	32

ii am sensitive

The new era of automation is based on sensitivity.

They can autonomously move, feel and collaborate directly with humans. They can tend machines and transport tools. Thanks to integrated sensors, robots are fundamentally changing the production processes of the future. Never before have humans and machines been able to cooperate in such a seamless and direct manner. But this is not the only factor driving this radical industrial change.

The sensory capabilities of intelligent robots reach far beyond the immediate vicinity of the workpiece and the operator. They orient themselves independently in their surroundings and move into position for new automation tasks with millimeter precision. As a result, they are also changing the entire production environment. The smart factory of tomorrow is changing with each new requirement and is removing limits on productivity.



7

In all seven axes, the LBR iiwa has joint torque sensors, implemented using safe technology.

The key to innovative automation solutions. Sense, detect, respond according to the situation and join parts intelligently. With its integrated torque sensors, the LBR iiwa enables the automation of delicate assembly tasks for force-controlled joining operations and process monitoring. The controller is optimized for this, simplifying the fast start-up of even complex applications. The robot becomes the third hand of the human operator.

Green light for innovative automation solutions. In today's manufacturing environment, the ever-increasing diversity of products and variants means that the utmost in flexibility and adaptability is required. Furthermore, the phenomenon of an ageing workforce is making it necessary to come up with new answers in the field of automation. The LBR iiwa provides them. It is laying the foundation for innovative, future-proof production processes – more ergonomic, more efficient and more cost-effective.

1:2

The sensational payload-weight ratio of the LBR iiwa with a 14 kg payload is 1:2.

23.9 /
29.9 kg

Its low weight of just 23.9 kg (with a payload capacity of 7 kg) or 29.9 kg (with a payload capacity of 14 kg) is a key to the sensitivity and mobility of the LBR iiwa.

ii am sensitive

A revolution in robotics. The LBR iiwa has integrated, sensitive joint torque sensors in all seven axes. These endow the lightweight robot with contact detection capabilities and programmable compliance. It masters force-controlled joining operations and continuous-path processes for which the position of the objects must be sensed. In many cases, the integrated sensitivity of the LBR iiwa allows the use of simpler and less expensive tools.

Protection of materials and machines. Compliance of the LBR iiwa can be programmed individually for all joints as well as for all Cartesian degrees of freedom. The LBR iiwa is thus able to handle sensitive parts safely and assemble them by exerting exactly the right force, thereby avoiding rejects or costly collisions.

Agile due to lightweight construction and extremely short response times. As a result of its advanced lightweight design, the LBR iiwa only has to move small masses. Combining this with high-performance servo control, it is able to follow contours quickly under force control.

> 30,000_h

The ultimate in high-tech: despite its lightweight design, the LBR iiwa robot is suitable for use in industrial applications. The mechanical system and cables are rated for at least 30,000 hours of operation.

IP 54

The LBR iiwa is suitable for operation in normal machine environments and meets the requirements of protection rating IP 54.



With its integrated torque sensors, the LBR iiwa enables the automation of delicate assembly tasks for force-controlled joining operations and process monitoring.



The controller is optimized for this, simplifying the fast start-up of even complex applications. The robot becomes the third hand of the human operator.

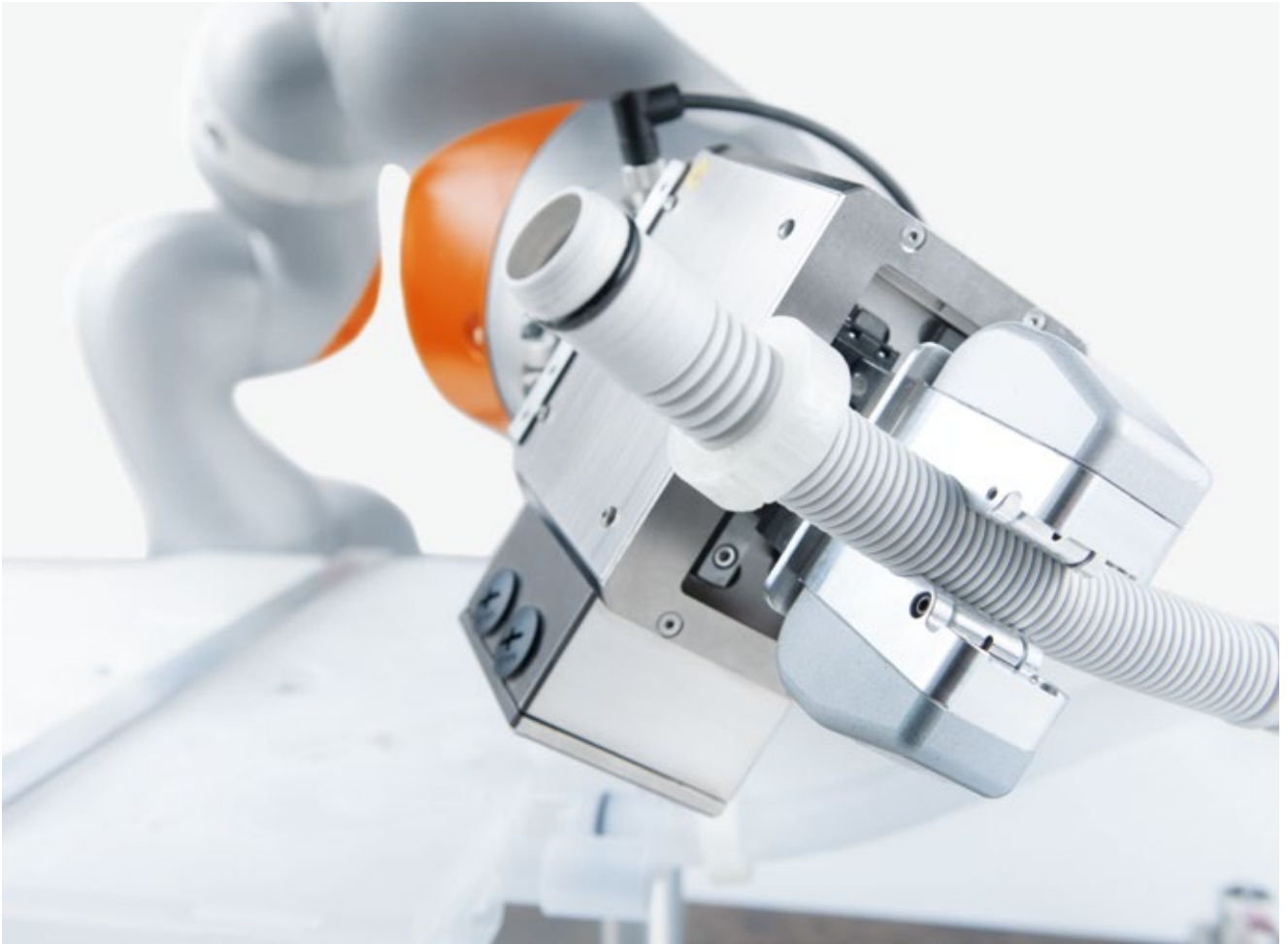

ii am sensitive

In practice

The LBR iiwa in production at Bosch Siemens Hausgeräte. For precise screwed connections for dishwashers, Bosch Siemens Hausgeräte relies on an innovative mobile automation solution with the LBR iiwa. If the component concerned is not perfectly adjusted, the robot recalibrates the dishwasher housing. For this, it develops a search strategy for the screw positions and recalculates them.

Greater productivity through self-mastering robotics. Using its sensitive properties, the robot can then calibrate itself independently at its workstation. It uses search run mode to locate the screw positions, carry out fine adjustment of the part and tighten the four screws. Particularly advantageous: the workplace does not have to be changed since the robot adapts flexibly to its surrounding conditions.



Thanks to its sensory capabilities, the LBR iiwa independently and reliably moves to the exact position of the workpiece to perform sensitive assembly tasks.



ii am safe

The LBR iiwa also takes safety to a whole new level.

Change is often known as the only constant. This is particularly the case for the profound change brought by the Internet of Things (IoT) and Industrie 4.0. For those wanting to be on the safe side, options have to be kept open.

It is precisely this safety which KUKA provides through intelligent technology which operates proactively. In the specific production process, this takes the form of frequent changes in automation tasks which require safe human-robot collaboration as well as reliable functioning and constant performance. Safety to a large extent means technology that is seamlessly networked with all the components of digitized industry.



EN ISO 13849

The safety functions of the LBR iiwa meet the requirements of Performance Level d with structure category 3. This enables safe human-robot collaboration.

Pioneer for safe human-robot collaboration. In all seven axes, the LBR iiwa has integrated joint torque sensors, implemented using safe technology. This is unique worldwide. They respond to the slightest of external forces and enable safe collision protection. In the case of unexpected contact, the LBR iiwa reduces its velocity in an instant, thereby limiting its kinetic energy to a level that precludes injuries.

The need for a safety fence is eliminated. So too are many associated costs. Where humans and robots collaborate safely, many safety precautions become superfluous. The LBR iiwa already incorporates all necessary measures in its HRC package. Additional costs that are normally required for safety equipment, circuitry and safety fences, and the associated space requirements, are eliminated. Humans and robots can share the same workspace and optimally divide tasks between them. This also makes it possible to dispense with expensive feed systems and production areas.

Teaching by demonstration. The LBR iiwa enables the easiest kind of programming. The operator guides the robot by hand to the desired positions, while the coordinates of points moved to on the path are saved in the robot program. The conditions are thus perfect for cost-effective automation, even in the case of small batch sizes or large product variety.

Intuitive operator control simply through gestures. The safe torque sensors enable the sequence of a robot application to be controlled without control equipment and simply through gestures – for example, by touching the robot.

Sensitized for safe working. Due to a wide range of safety functions, such as safe collision and force detection, safely reduced velocity and safe monitoring spaces of the LBR iiwa, in accordance with performance level d, category 3 the system integrator is able to implement standard-compliant robot applications with HRC.

A new form of safety. The housing of the LBR iiwa is made entirely of aluminum. This reduces weight and increases safety. Thanks to its streamlined design without edges, the LBR iiwa also eliminates all crushing and shearing hazards. This minimizes risks when working with humans. The products fulfill the requirements of functional safety according to DIN EN 62061 up to SIL 2 and EN ISO 13849 up to Performance Level d performed in Category 3.



High sensitivity is a prerequisite for the safety of humans and materials. The LBR iiwa is extremely responsive.



The products fulfill the requirements of functional safety according to **DIN EN 62061** up to **SIL 2** and **EN ISO 13849** up to Performance **Level d** performed in **Category 3**.



ii am safe In practice

The LBR iiwa in use in KUKA robot production. For the production of the KR QUANTEC robot, KUKA developed a versatile solution to make a non-ergonomic workplace more productive. The HRC system controlled using gestures sensitively distinguishes between components and independently calibrates itself to determine its position. The LBR iiwa then fastens 36 or 30 inserted screws on four housing variants with a torque of 104 Nm and documents the work steps through the screw driver control.

Optimized productivity in human-robot collaboration. The LBR iiwa pushes against the gear unit and is thus able to achieve the torque required for the screw fastening. In this way, it can reach all screw positions without any restrictions. The trade association-certified system thus helps to boost productivity using direct collaboration with humans.



The HRC-capable LBR iiwa works hand in hand with humans and, as a result, is revolutionizing industrial production and manufacturing.



ii am flexible

The age of individuality is changing industries.

In the factory of the future, the focus of thought and action will shift to the human worker with his individual desires, requirements and capabilities. This also applies in his role as consumer and as sought-after employee.

Whereas until now the primary focus was on mass production at the lowest possible unit costs, the industrial production of the future will be primarily shaped by demand for products which are high in quality and simultaneously highly customized. Meeting this demand will require innovative automation solutions, which are now made possible by intelligent KUKA robotics. They enable companies to design the digital transformation of their production processes in a highly flexible and efficient manner.

With the LBR iiwa, the industry gains many new fields of application.

The kinematic system is based on the human arm and can reach the position and orientation of the tool with different axis positions. It simply reaches round disruptive contours. In this way, work sequences can be programmed in an extremely space-saving manner. Particularly in the case of confined and difficult installation situations in production systems, the LBR iiwa proves its worth as a highly flexible work assistant.

Seven axes for maximum versatility. The low weight of the sensitive LBR iiwa lightweight robot, its small footprint and enormous payload predestine it for mobile operation. Mounted on a carriage as a job-hopper, it can work in constantly changing locations depending on specific requirements – in collaboration with the human operator or alone. On arrival at its place of operation, it makes use of its integrated sensitivity to calibrate itself automatically and precisely.

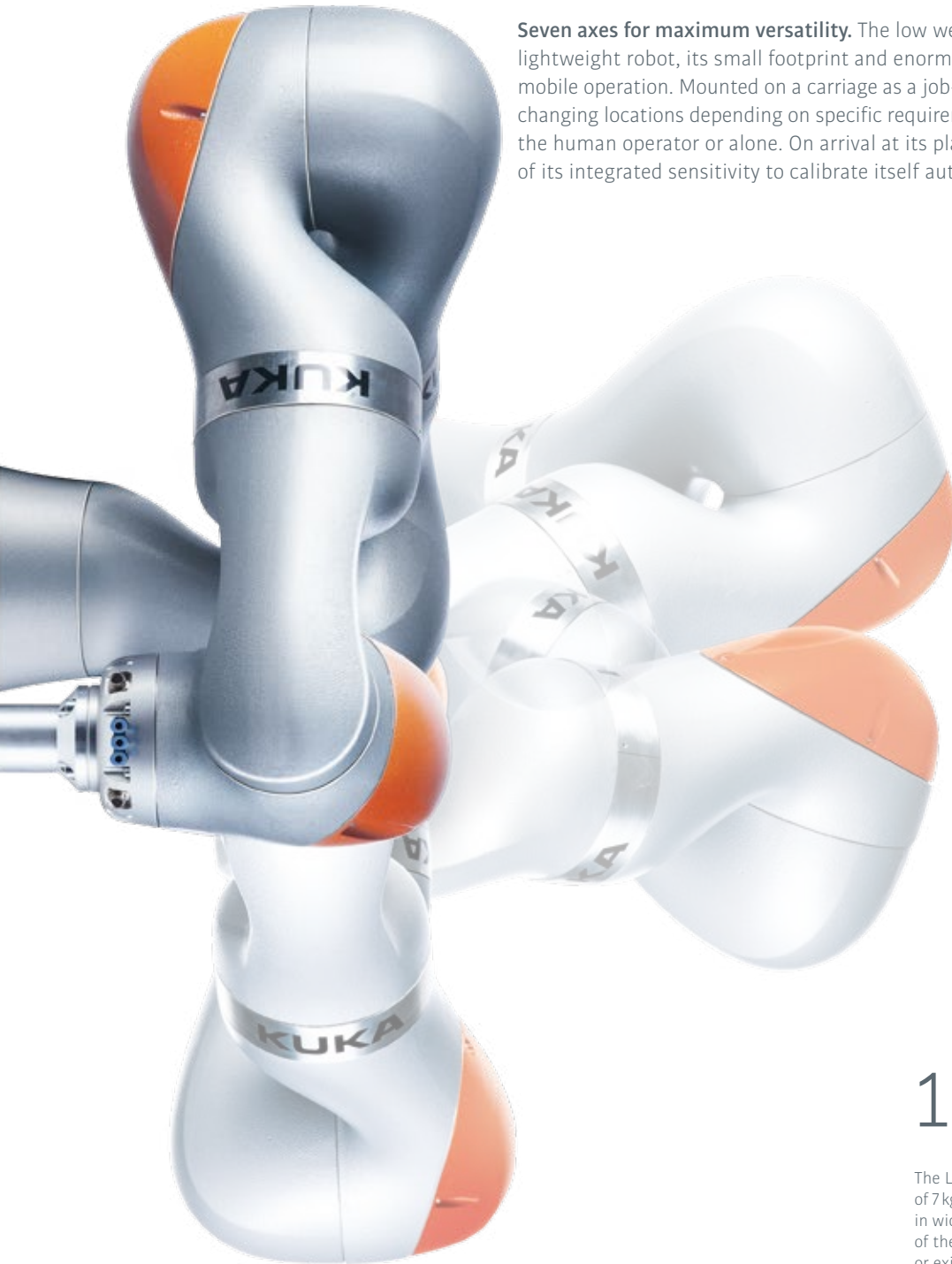

136_{mm}

The LBR iiwa with a payload capacity of 7 kg has a footprint of just 136 mm in width, thereby simplifying integration of the robot into mobile solutions or existing systems.

ii am flexible

The LBR iiwa plays a central role in production scenarios of the future. And it is preparing the way for the highest levels of customization – right down to batch size 1. At the same time, it is modular, open and easy to program, thanks to consistent use of Java technology. The globally used programming language enables the quick expansion of available libraries through external, and often free, open-source software. In this way, companies acquire tangibly greater flexibility for the planning and implementation of their automation processes.

In “Position controller” mode, the LBR iiwa moves to the desired positions with the programmed velocity. In “Gravity compensation” mode, it compensates the load so that it can be moved by exerting a minimum of external force. In “Compliance control” mode, the compliance can be configured translationally and rotationally as well as independently in each axis.

The environment changes, the performance stays the same. The LBR iiwa orients itself independently and expands its working range almost without limit using mobile platforms such as KUKA Mobile Robotics. This reduces the complexity of the periphery and enables uncomplicated, cost-effective tools. The compliance required when working is now achieved by the LBR iiwa and can be quickly adjusted to new requirements through a parameter change.

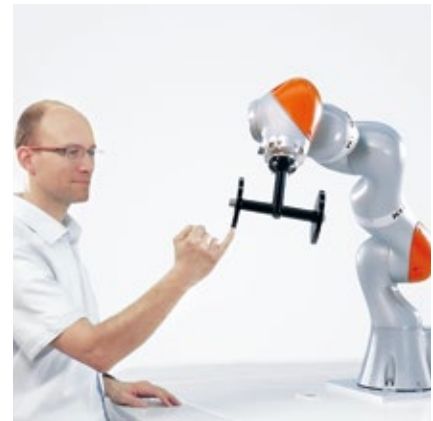

KUKA Mobile Robotics iiwa

The combination of mobile platform and intelligent, sensitive work assistant opens up a wide range of potential applications.

Rack storage

Thanks to its innovative navigation system, the KMR iiwa operates autonomously and is able, for example, to set down machined workpieces or independently fetch required components.

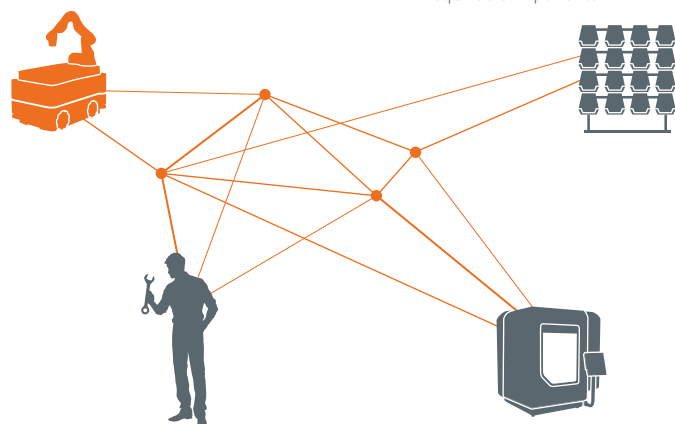

Operator

The operator is relieved of monotonous, non-ergonomic tasks and can concentrate on important processing steps.

Machine tool

The KMR iiwa takes over the tending of machine tools and relieves the human worker of strenuous and tiring tasks.



ii am flexible In practice

The LBR iiwa in use at Siemens AG. At Siemens in Bad Neustadt, Germany, the LBR iiwa robot handles the automated loading and unloading of a CNC Turning Machine. The many tasks it masters include: gripping the stator housing, removing the swarf, setdown into the measuring device and removal and setdown into OK and NOK small load carriers. It also automatically identifies the 29 housing variants, carries out handling of small load carriers onto the roller conveyor and performs automatic calibration.

Greater versatility and a better working environment thanks to flexibility.

The LBR iiwa as a central automation robot enables the development of a highly adaptable system. It can be quickly and easily expanded for further housing variants and noticeably improves the working conditions for employees in the manufacturing process.



Humans and robots collaborate optimally –
without separation or safety fencing.

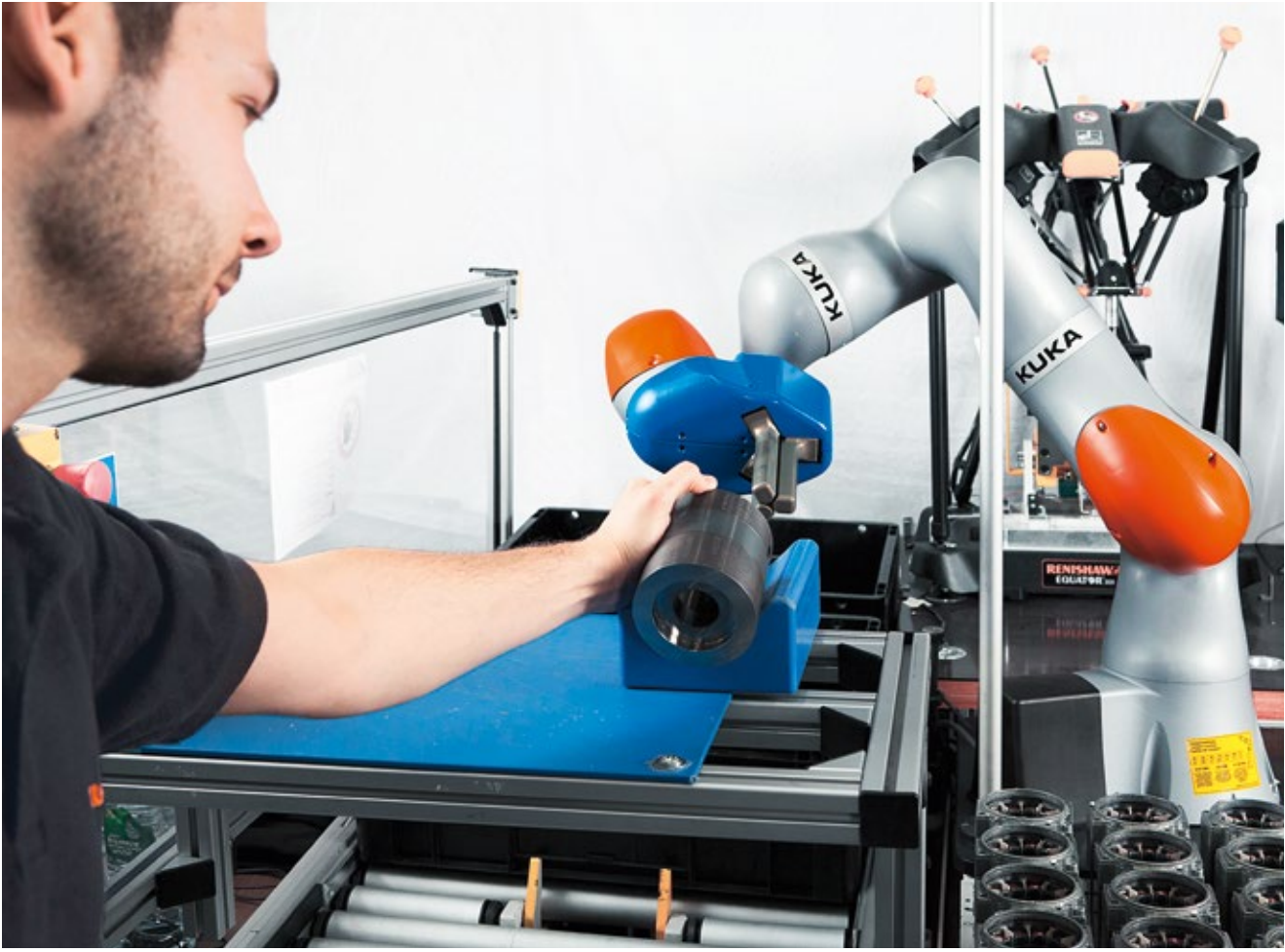

ii am precise

Envisioning the industrial future with precision

The term precision ordinarily describes the accuracy with which a machine operates. KUKA robotics achieve precisely that – but also much more: KUKA delivers conceptual precision with a view to the requirements of an increasingly digitized and networked industry. After all, KUKA automation technology is based on knowledge of industry requirements as well as the market and production environments. It includes coming requirements such as networking capability and manufacturing flexibility.

In this way, KUKA is playing a decisive role in shaping the Industrie 4.0 as well as intelligently bringing the expertise from the real world and the digital world together.

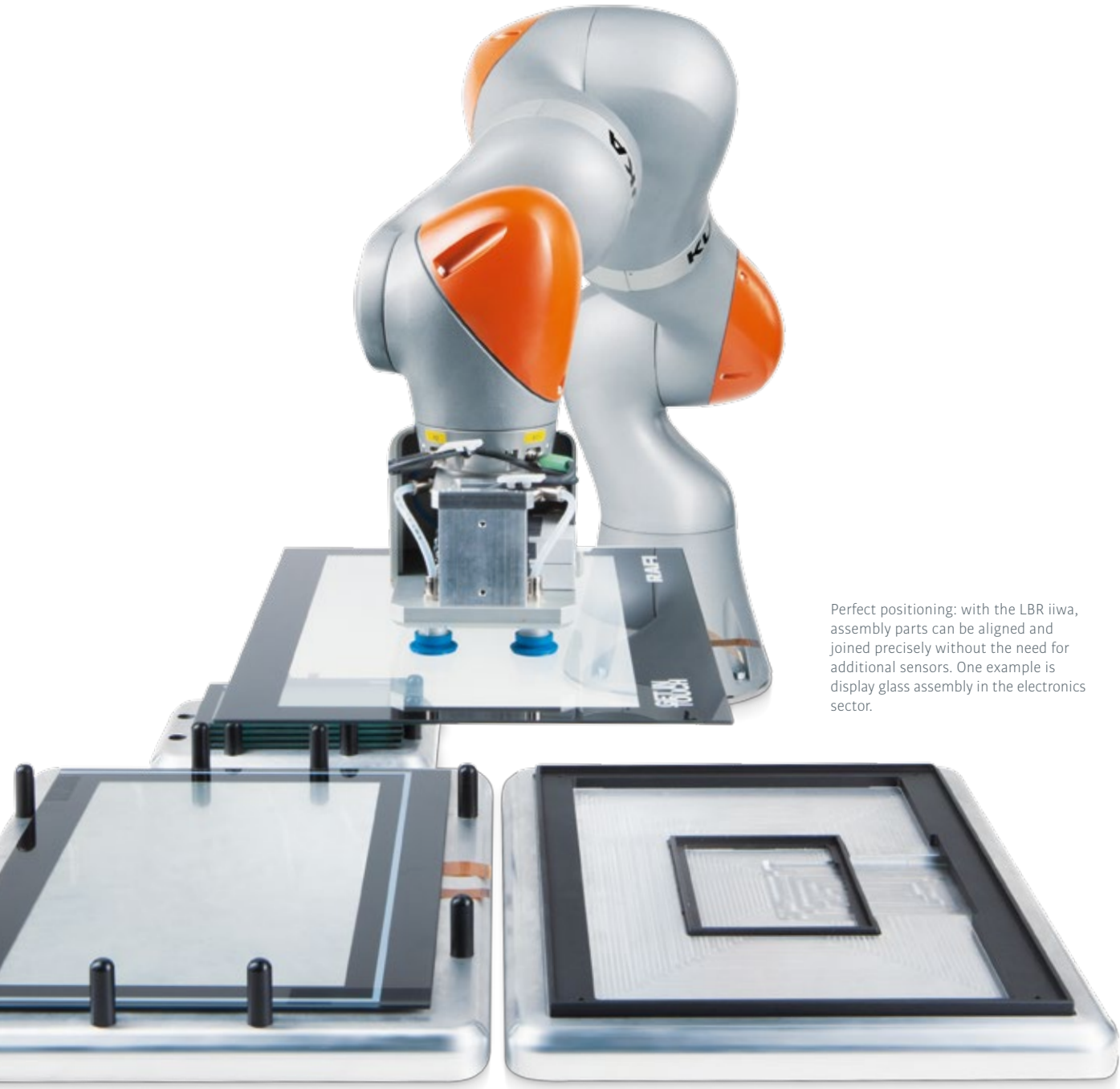

Perfect positioning: with the LBR iiwa, assembly parts can be aligned and joined precisely without the need for additional sensors. One example is display glass assembly in the electronics sector.

The LBR iiwa works with uncompromising accuracy. Processes that can be traced in detail. When the LBR iiwa carries out automation tasks, it can continuously record process parameters and forces in parallel. Its precise work can thus be traced at all times without the need for time and cost-intensive external quality controls. This, in turn, makes automation processes significantly simpler and more flexible.

Lowest tolerances, high path accuracy. All gear units of the LBR iiwa are systematically designed for precision and manufactured with extremely low tolerances. This results in a high repeatability of ± 0.1 mm. The uniquely smooth running of the LBR iiwa is achieved by taking the torque signals into consideration during path control. This precision qualifies it for demanding assembly tasks which it is able to perform like no other industrial robot in the world.

± 0.1 mm

The repeatability of the LBR iiwa is ± 0.1 mm. This makes it suitable for complex assembly tasks.

ii am precise

Precisely on track, even in the case of changing workpieces. Thanks to its compliance, the LBR iiwa can trace and process irregular surfaces without the need to program the path precisely or position workpieces exactly. The robot sensitively and autonomously follows the contour without penetrating surfaces or losing contact. The LBR iiwa automatically compensates for irregularities in the workpiece. Furthermore, a better cycle time is achieved because the motion to the point of contact can be carried out at a higher velocity than with conventional industrial robots.

Integrated media, perfected flange. The LBR iiwa is the preferred assistant for complex assembly tasks and in confined installation situations. In order to avoid disruptive contours, all media are routed entirely internally through the robot arm – all the way from the base to the innovative flange. Only there, in the immediate vicinity of tools or mounted sensors, are the power and compressed air supply lines and field buses routed out of the robot. The media flange is available in electric and pneumatic variants.

Fast orientation: Even if parts have not been positioned accurately, the LBR iiwa can locate them, pick them up correctly and join them with the utmost precision.

Precise assembly: In the assembly of torque converter transmissions, the LBR iiwa positions delicate converter blades with uncompromising precision, without the need for complex tools, external sensors or actuators.



Exactly the right part: Even if assembly parts are not precisely positioned, the LBR iiwa can detect their position and assemble them perfectly.



ii am precise In practice

The LBR iiwa at the BMW Group's Dingolfing plant. Integrated into a minimum of space, this automation solution relieves the stress on the operator during the assembly of differential cases for front-axle transmissions. Previously, the parts, which weigh up to 5.5 kilograms and are difficult to grip, had to be fitted with millimeter precision by hand. Thanks to human-robot collaboration, this ergonomically challenging work can be carried out with utmost precision in less than 30 seconds. Beyond this, the operator is protected from injury at all times by an HRC case and by the sensitive technology of the lightweight robot.

Ceiling-mounted variant for minimum space requirements. A sleek steel structure mounted on the ceiling secures the lightweight robot and allows it to work with high efficiency. It can be integrated into the existing production line without further conversion. Sufficient space is also available for the compact control cabinet with interfaces to the system controller.

Improved job quality through HRC solutions. The operator places all of the small and lightweight parts, such as spacers and ball bearings, into the transmission case and the cover. The operator then presses a button to activate the robot, which carefully fits the heavy differential case in place and ensures that the sensitive tooth flanks are not damaged by impacts when meshing the gears. The operator then fastens the cover to the transmission.



The human operator and the robot collaborate to install differential cases for front-axle transmissions. Once the lightweight parts are adjusted by hand, the robot then takes over and precisely fits the heavy ring gear.

The gripper, as the end effector of the robot, has been equipped with an edge-free HRC case with a rounded design so that the gripper too is HRC-compatible and the operator is protected from injury at all times.



Technical data

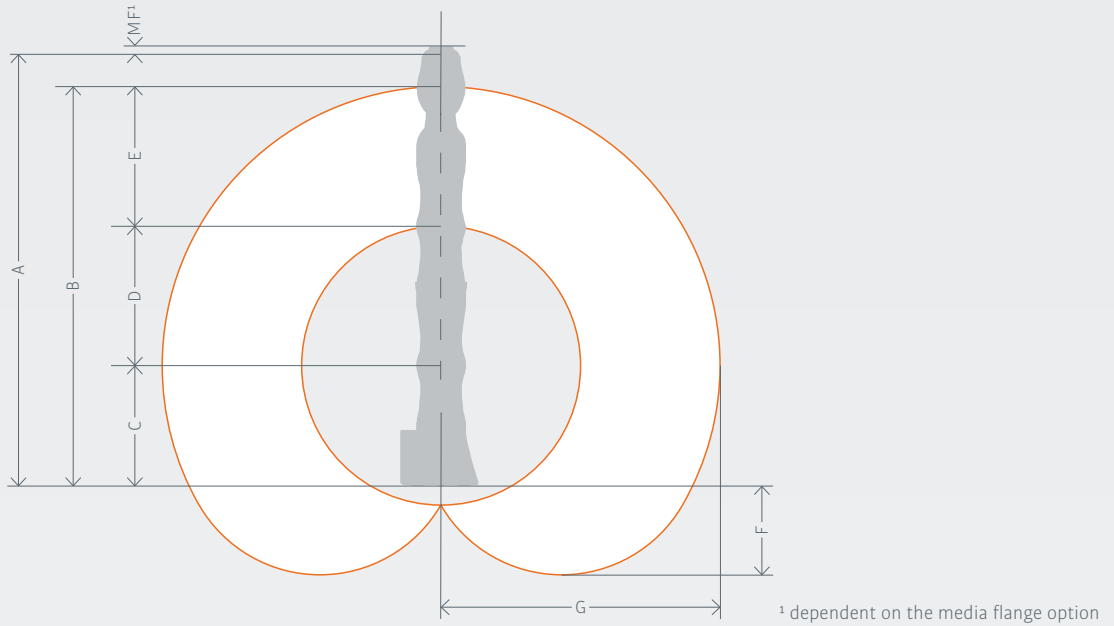

Workspace	Dimensions A	Dimensions B	Dimensions C	Dimensions D	Dimensions E	Dimensions F	Dimensions G	Volume
LBR iiwa 7 R800	1,266 mm	1,140 mm	340 mm	400 mm	400 mm	260 mm	800 mm	1.7 m ³
LBR iiwa 14 R820	1,306 mm	1,180 mm	360 mm	420 mm	400 mm	255 mm	820 mm	1.8 m ³

LBR iiwa	LBR iiwa 7 R800	LBR iiwa 14 R820
Rated payload	7 kg	14 kg
Number of axes	7	7
Wrist variant	In-line wrist	In-line wrist
Mounting flange A7	DIN ISO 9409-1-A50	DIN ISO 9409-1-A50
Installation position	any	any
Positioning accuracy (ISO 9283)	± 0.1 mm	± 0.1 mm
Axis-specific torque accuracy	± 2 %	± 2 %
Weight	23.9 kg	29.9 kg
Protection rating	IP 54	IP 54

Axis data / Range of motion		Maximum torque	LBR iiwa 7 kg Maximum velocity	Maximum torque	LBR iiwa 14 kg Maximum velocity
Axis 1 (A1)	± 170°	176 Nm	98°/s	320 Nm	85°/s
Axis 2 (A2)	± 120°	176 Nm	98°/s	320 Nm	85°/s
Axis 3 (A3)	± 170°	110 Nm	100°/s	176 Nm	100°/s
Axis 4 (A4)	± 120°	110 Nm	130°/s	176 Nm	75°/s
Axis 5 (A5)	± 170°	110 Nm	140°/s	110 Nm	130°/s
Axis 6 (A6)	± 120°	40 Nm	180°/s	40 Nm	135°/s
Axis 7 (A7)	± 175°	40 Nm	180°/s	40 Nm	135°/s

Programmable Cartesian stiffness

Min. (X, Y, Z)	0.0 N/m	0.0 N/m
Max. (X, Y, Z)	5,000 N/m	5,000 N/m
Min. (A, B, C)	0.0 N/rad	0.0 N/rad
Max. (A, B, C)	300 Nm/rad	300 Nm/rad

KUKA Sunrise Cabinet

Processor	Quad-core processor
Hard drive	SSD
Interfaces	USB, EtherNet, DVI-I
Protection rating	IP20
Dimensions (D x W x H)	500 mm x 483 mm x 190 mm
Weight	23 kg

Power supply connection

Rated supply voltage	AC 110 V to 230 V
Permissible tolerance of rated voltage	± 10 %
Mains frequency	50 Hz ± 1 Hz or 60 Hz ± 1 Hz
Mains-side fusing	2 x 16 A slow-blowing

30,000 operating hours



Media flange options

The energy supply system for the external components of the LBR iiwa is hidden in the kinematic structure of the robot. Two energy supply systems are available:

Pneumatic

2 x air (diameter 4.0 mm)
 2 x electrical (1.0 mm²)
 1 x EtherNet-capable cable

Electrical

3 x twisted two-wire cables (AWG28)
 4 x electrical (1.0 mm²)
 1 x EtherNet-capable cable

All media flanges have a hole pattern conforming to DIN ISO 9409-1-50-7-M6. The following media flanges are available:

	Basic flange	Media flange electrical	Media flange pneumatic	Media flange IO electrical	Media flange IO pneumatic	Media flange Touch electrical	Media flange Touch pneumatic	Media flange IO valve pneumatic	Media flange Inside electrical	Media flange Inside pneumatic
Interface for CAT5 and analog signals (4 pins)		●	●						●	●
Interface for CAT5 and analog signals (6 pins)		●		●		●			●	
Interface for energy supply system (3 A, 24 V), no external power supply required				●	●	●	●	●		
Interface for energy supply system (max. 4 A, max. 60 V) with external power supply				●		●				
Interface for energy supply system (max. 5 A, max. 60 V) with external power supply		●							●	
Interface for energy supply system (max. 8 A, max. 30 V) with external power supply			●							
Interface for energy supply system (max. 8 A, max. 60 V) with external power supply		●							●	●
Pneumatic interface with 2 compressed air connections			●		●		●			●
EtherCAT connection				●	●	●	●	●		
Configurable inputs and outputs for direct connection of sensors and other electrical components				●	●	●	●	●		
Enabling switch, programmable application switch, programmable visual display (LED)						●	●			
Grip for manual mode						●	●			
Intelligent pneumatic interface: 2 integrated bistable valves and 1 additional air connection								●		

Programming.
Control. Operation.

Java technology

The LBR iiwa controller exclusively uses Java technology for sequence programming – for maximum modularity, openness and simplicity.



Programmed for success: KUKA Sunrise.Workbench.

The new KUKA Sunrise.Workbench engineering suite for programming, start-up and debugging. It makes operator control of the LBR iiwa more intuitive and userfriendly than ever before. Programmers receive active support, for example, from the integrated handbook, the auto-complete function and the highlighting of syntax and errors in the program code.

Controlling the future:

KUKA Sunrise. The basis for the innovative LBR iiwa robotics consists of the specially developed KUKA Sunrise control technology, the KUKA Sunrise Cabinet control hardware and the KUKA Sunrise.OS control software.

KUKA Sunrise Cabinet unites safety control, robot control, logic control and process control of the entire system. Its interfaces, scalability, performance and openness mean that there are virtually limitless automation possibilities. In the future, it will also be possible to control multiple lightweight robots with a single controller.

KUKA smartPAD with new user interface.

Just as intelligent as the way the LBR iiwa works is the way it can be operated. With the tried-and-tested KUKA smartPAD and its redesigned user interface. Tiles with self-explanatory icons lead intuitively to the desired functions, while colored status LEDs provide fast feedback about the current status of the robot station.

More detailed information and problem solutions are never more than a few clicks away. Thanks to multiple visualization functions, the KUKA smartPAD simplifies work and boosts both safety and productivity.

